

Falls Creek Alpine Resort Management Board Water Quality Annual Report



2020/21

Falls Creek Resort Management
ABN 21 789 770 569
1 Slalom Street, Falls Creek VIC 3699
PO Box 50, Falls Creek VIC 3699

T: 03 5758 1200
E: fcrm@falls creek.com.au
W: falls creek.com.au



Foreword

Falls Creek Alpine Resort Management Board (FCARMB) is a crown land manager, a major tourism destination and home to a vibrant growing year-round community.

At the core of its purpose, the Board provides essential services to business operators, visitors and guests and its local community. Whilst also developing, promoting, and using the resort in a sustainable manner and recognising the environmental and ecological significance of its surroundings.

We recognise the vital role visitation by patrons to this award-winning tourism destination plays in the sustainability of on-mountain businesses. Circumstances throughout this year however required an elevated degree of resilience to bear the brunt of bushfire recovery and the global COVID-19 pandemic, forcing the resort to close to the public on numerous occasions, creating unprecedented disruption, financial hardship, and significant challenges for its community.

Even so, during these extraordinary times, our staff and the community rallied and played an essential role in both rebuilding and revitalising the resort, building back from the disruption and preparing to welcome the many hundreds of thousands of visitors and guests who journey to Falls Creek.

Nonetheless, FCARMB must still deliver essential services and provide assistance for our people and community, including the provision of safe drinking water under specific COVID-19 Safety Plan requirements.

Water supply at Falls Creek is a combination of high-altitude aquifers extracted via groundwater bores and use of the Rocky Valley reservoir. Both sources are incredibly pure alpine water, driven by snow melt and largely untouched by human activity.

Once again throughout the 2020-21 period the quality of water provided by the resort to its constituents was exemplary. There were zero E coli detections across the year and the operational delivery was expertly managed by our team.

We thank the Victorian State Government and Falls Creek Alpine Resort Management Board members for the dedication through this tumultuous year, along with our resilient stakeholders and lastly, our committed and agile staff for their extraordinary contribution not only for the organisation, but also for our community.



Stuart Smythe
Chief Executive Officer
Falls Creek Alpine Resort Management Board

Table of Contents

Legislative Background and Purpose	4
Introduction	4
1 Overview	6
1.1 Water Supply System	6
1.1.1 Overview	6
1.1.2 Classification of Raw Water Sources	7
1.1.3 Groundwater Sources	9
1.1.4 Back up Rocky Valley Dam supply – Surface Water	10
1.1.5 Header Storage Tanks (Brown and Blue Tanks)	11
1.1.6 UV Treatment	11
1.1.7 Reticulation system	12
1.2 Implications for Risk Management	12
1.2.1 Groundwater Supply	12
1.2.2 Rocky Valley Dam Backup Supply	12
1.3 Implications for Emergency Management	13
1.4 Demand	13
2 Drinking Water Treatment Processes – r. 16(e)	15
2.1 Water Treatment	15
2.1.1 Accumulation Tank and Calcite Filter	15
2.1.2 UV Treatment	15
2.2 Issues	16
2.3 Chlorine based disinfection by-product chemicals	16
3 Emergency, Incident and Event Management - r. 16(a) & 16(b)	17
3.1 Known or Suspected Contamination Reported Under Section 22	17
3.2 Situations not reportable under s. 22 which impacted or had the potential to impact the water quality, but not the safety, of the water supplied	17
3.3 Staff and Resourcing for Water Operations Department	18
4 Drinking Water Quality Standards – r. 16(f), 16(g) & 16(h)	19
4.1 Safe Drinking Water Regulations 2015	19
4.2 Schedule 2 Drinking Water Quality Standards – r. 12(a)	19
4.2.1 Escherichia coli (E. Coli)	19
4.2.2 Turbidity	19
4.3 Other water quality parameters monitored that may pose a risk to human health – r. 12(b)	20
4.4 Drinking Water Quality Reports – s. 23	21
4.5 Actions in Relation to Non-Compliance	24
5 Aesthetic Guidelines	25
5.1 Actions undertaken where aesthetic guideline value is not satisfied.	26
6 Water Quality Complaints – r. 16(j)	26
7 Risk Management Plan Audit Results – r. 16(d)	27
8 Undertakings – r. 16(c)	29
9 Regulated Water – r. 16(l) & 16(m)	29
10 Glossary of Terms and Further Information	30

Legislative Background and Purpose

Section 26 of the *Safe Drinking Water Act 2003* (the Act) requires water suppliers and water storage managers to provide to the Secretary of the Department of Health (DH) an annual report each financial year. Falls Creek Alpine Resort Management Board ('FCARMB') is the water supplier for the Falls Creek Alpine Resort. This report is for the 2020-21 reporting period and covers issues relating to the quality of drinking water.

FCARMB's obligations under the Act include:

- A requirement to prepare, implement and review plans to manage risks in relation to drinking water;
- A requirement to have the risk management plan audited by approved auditors;
- To ensure that the drinking water meets quality standards specified by the regulations;
- To disclose to the public information concerning the quality of drinking water; and
- To report known or suspected contamination of drinking water to the Secretary of the DH.

Information to be included in the annual report is specified by regulation 16 of the *Safe Drinking Water Regulations 2015* (the Regulations).

Introduction

FCARMB is responsible for the development, promotion and management of the Falls Creek Alpine Resort which is located 120 kilometres south of the Albury/Wodonga area is situated at an altitude of 1210-1830 metres and is surrounded by the Alpine National Park.

The entire resort area of 1495 hectares is Crown land, which is deemed to be permanently reserved as an alpine resort under the *Crown Land (Reserves) Act 1978*. The Resort area is not part of any municipal district for the purposes of the *Local Government Act 1970* and the Board acts on behalf of the Crown under the direction and guidance of the Minister for Energy, Environment and Climate Change.

The Board is established by the *Alpine Resorts (Management) Act 1997* and *Alpine Resorts (Management) Regulations 2020* which sets out the objectives for the management of Victoria's alpine resorts.

The resort is set aside for alpine recreation and tourism. The development, promotion, management and use of the resort is to be undertaken in a manner which is compatible with the alpine environment having regard to economic, environmental, and cultural considerations. The village area supports administrative, retail, and commercial business as well as a large variety of accommodation.

FCARMB provides a range of services to the community and resort visitors determined by clearly defined functions under the Act. These include the provision of a range of utility services including the supply of drinking water.

Falls Creek Resort Management is committed to producing safe and aesthetically pleasing drinking water.

The village population, and consequent demand for water, is highly seasonal. The summer permanent population is around 200, with winter daily visitation exceeding 5000 people during peak periods.

This report outlines drinking water quality achieved for the 2020-21 financial year and has been prepared to provide our customers with information relating to the quality of water supplied and to comply with the annual reporting requirements under Section 26 of the Act. The report covers issues relating to the quality of drinking water and is structured in accordance with the Water Quality Annual Report Guidance issued by DH.

The report is divided into 10 sections:

1. Overview
2. Drinking Water Treatment Processes
3. Emergency, Incident, Event Management and Resources
4. Drinking Water Quality Standards
5. Aesthetic Characteristics
6. Water Quality Complaints
7. Risk Management Plan Audit
8. Undertakings
9. Regulated Water
10. Glossary of terms and further information.

1 Overview

FCARMB is continually striving to provide quality drinking water services for our customers and the most effective means of doing so is through a preventative risk management approach that encompasses all steps in water production from the catchment to the consumer.

Falls Creek Resort Management's drinking water risk management plan (RMP) discusses the measures adopted by the Resort Management Board to comply with the Act and the Regulations. There is a clear statement of executive commitment contained in Board Policy 1.30 (Safe Drinking Water) which acknowledges the organisation's obligations under the Act. FCARMB has approved and committed to the RMP. As a further demonstration of this commitment, the Corporate Plan recognises the Board's responsibility to implement an effective system for drinking water quality management. The FCARMB 2020 Annual Report acknowledges responsibilities under the Act and notes a range of FCARMB activities in complying with the requirements of the Act.

In recent years, FCARMB has undertaken several projects involving the commitment of substantial capital investment to improve the reliability and robustness of water quality management in the resort. The development of these activities indicates the practical commitment of FCARMB to continue to work to achieve safe drinking water within the resort.

Projects Executed in the FY2020-21 reporting period included

- New Back-up generator \$60,000
- SCADA monitoring software upgrades \$35,000
- Backup Hypochlorite Dosing system \$20,000
- New Security Cameras for water supply infrastructure \$10,000
- Walkway and lifting equipment for Calcite filtration system \$50,000

1.1 Water Supply System

1.1.1 Overview

The water supply system is comprised of the following elements:

- Two separate ground water sources
 - A vertical Production Bore
 - Horizontal Bore
- An Accumulation Tank for transfer through calcite filtration system
- Calcite Filter prior to the Header Tank to mitigate pH excursions
- 2 x 1.5 ML water storage tanks located above the village
- 2 x Wedeco Spektron 250e UV Disinfection units
- 4km (approx.) DICL reticulation pipework.

The surface water system is used primarily to supplement the ground water system during the peak winter demand. It is not used between September and May, the main summer period.

The surface water supply system is comprised of;

- An intake within the Rocky Valley Dam;
- A pumping station, that transfers water from the Dam to two Settling Tanks;
- Two Settling Tanks, which provided a means to allow any residual suspended solids to be removed
- A pipeline/gravity main to Blue and Brown storage tanks

1.1.2 Classification of Raw Water Sources

The recharge areas for Rocky Valley Dam and the Production Bore and the Horizontal Bores may be characterised as pristine catchments. They are within the boundaries of the Falls Creek Resort and surrounded by the Alpine National Park. These areas do not include any habitation, grazing, cropping, or other human industrial activities. They are at a higher altitude than the Falls Creek Village, meaning that they are not polluted by any wastewater emanating from the village. While they are accessible to hikers in summer and skiers in winter, there is little evidence of rubbish dumping or vandalism. They contain populations of native and feral fauna, but these animals do not aggregate into significant herds. There are negligible sources of protozoan pathogens in the recharge areas.

The Production Bore and the Horizontal Bores are well sealed to prevent ingress of surface run-off water. However, given the fractured nature of the geology, a pessimistic view is warranted, and the groundwater has been assessed as if it were surface water. Even so, the above factors suggest that the groundwater may be expected to be devoid of any substantial microbial or chemical contamination. This has been borne out by groundwater analyses conducted to date, which show soft water with no microbial contamination and very low concentrations of dissolved solids.

There have been no recorded incidences of algal problems in the Rocky Valley Dam supply. The likely reason for this is that inflows are low in nutrients and the low temperature of the lake water, which generally lies in a range between 0°C and 16°C.

Recreational boating under strict conditions is permitted on the lake in summer months. There are designated access areas for boats. Boating near the water supply offtake is not permitted. The huge dilution factor associated with the lake provides substantial mitigation in the event of any fuel spill contamination. The low water temperatures result in very limited participation in swimming. While the lake is openly accessible to the public, the supply infrastructure is inspected regularly and there is no history of vandalism.

Microbial Assessment

Microbiological sampling of raw water from the groundwater sources has been undertaken since 2015. While this is a short time-frame in terms of water quality monitoring, the results to date show no detectable *E. coli* in 100 ml samples.

Long term microbiological sampling data of raw water from Rocky Valley Lake typically show no detectable *E. coli* in 100 ml samples and what detections there are typically show single digit concentrations per 100 ml. The average reading for the last 3 years is one *E. coli* per 100ml sample and the range is from zero to 9.

In summary, the sanitary survey and vulnerability assessment suggests that both raw water sources conform to the Category 1 in the WSAA Manual.

Figure 1 - Diagram of supply system

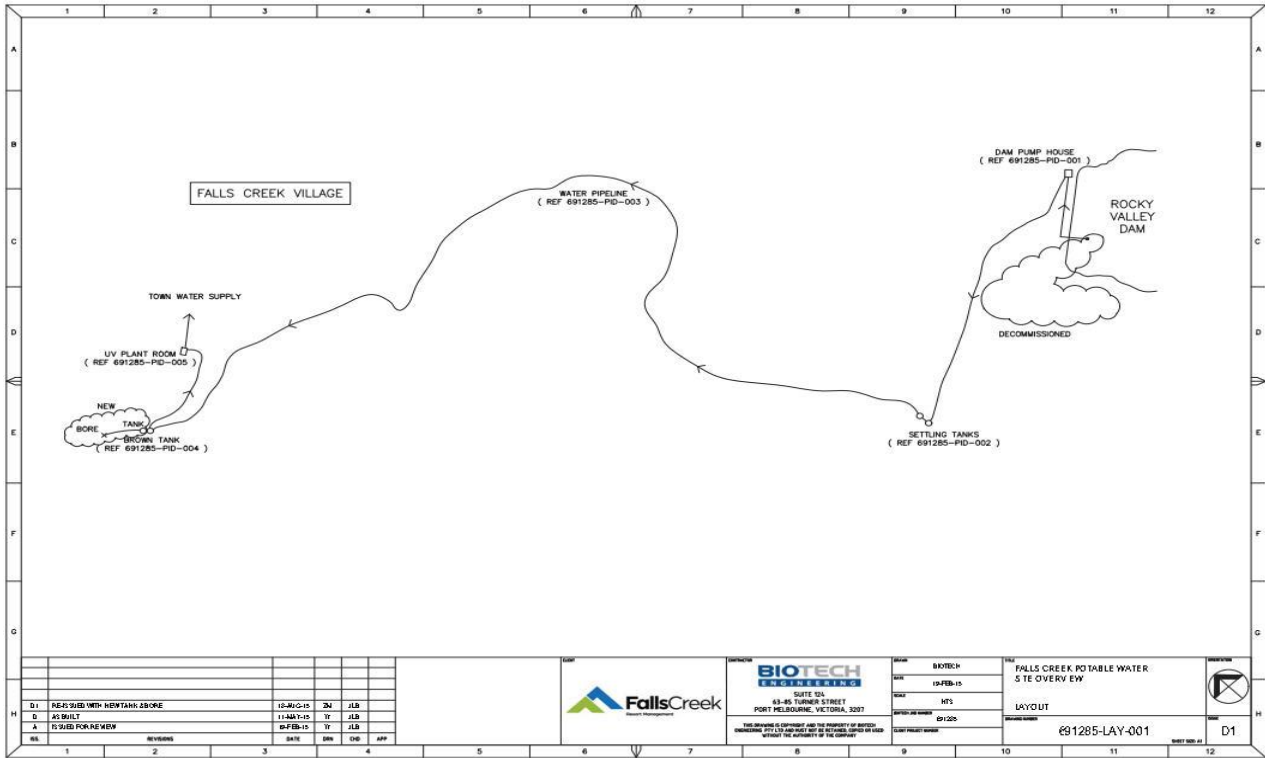
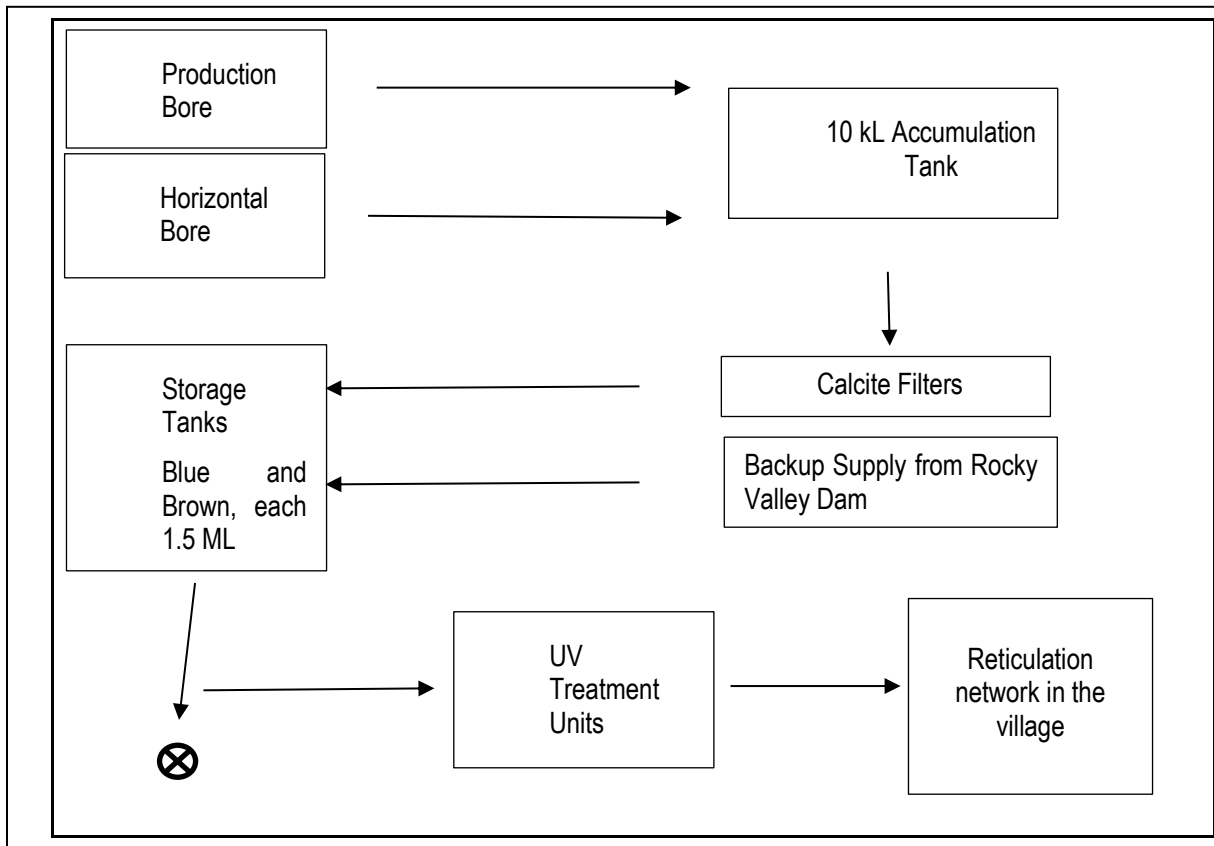

Figure 2 Schematic Diagram of Bore, Horizontal Drains, Accumulation Tank, Calcite Filter, Header Tanks, UV system and UV By-pass.



1.1.3 Groundwater Sources

Geological and hydrogeological studies have been undertaken by FCARMB for over a decade as part of the geotechnical risk management program. As part of these investigations, several horizontal bores were installed throughout the village. These bores were identified as a potential water source for the village. Vertical drilling was undertaken in 2014 to further study geological structures identified from geophysical mapping. Based on the results of the vertical drilling, a groundwater Production Bore was installed at a point identified as a high yield location.

Production Bore

Approval for the Production Bore was obtained from the Designated Authority, Goulburn-Murray Water (GMW). Conditional licence for groundwater extraction and the licence for the drilling and construction of the production bore were obtained. It is a condition of the licence that bores must be constructed to prevent aquifer contamination caused by vertical flow outside the bore casing and the bore head must be constructed to ensure that no flood water, surface runoff or potential subsurface contaminated soakage can enter the bore. The Production Bore was commissioned in 2016. It sources groundwater from a depth of 60 metres below ground level and pumps from a depth of 53 metres.

In keeping with the licence requirement, the bore is well sealed against ingress of surface and sub-surface water with a concrete pit and air-tight seal (Gatic). Concrete grout has been installed around the casing to a depth of 16 m. Below this, 2m of bentonite has been installed to seal the bore and support the grout. Below the bentonite, gravel packing has been placed between the borehole and the casing.

SCADA records of water level in the bore demonstrate that there is an expected decrease in response to pumping. While the nature of the fractured geology allows the bore to recharge quite quickly, no sudden rises in water level or sudden falls in turbidity have been observed after rain events confirming no surface water ingress. The groundwater, however, should be assumed to be under the influence of surface water because of the fractured geology. The water from the bore is tested weekly by a NATA accredited laboratory, so any changes in water quality will be identified immediately.

The bore is situated a very short distance from the Storage Tank complex (Brown and Blue). The pipework linking the Production Bore with the Storage Tank complex is entirely underground which substantially reduces the risk of human interference.

Horizontal Bores

A Horizontal Bore is also linked to the Drinking Water Supply. This bore is part of a system of bores that were constructed to facilitate hydrostatic depressurisation of geological features in the vicinity of the Falls Creek village.

As these bores are horizontal, the risk of contamination from surface runoff and subsurface contaminated soakage is reduced. These bores and the associated surface casings are positioned either below ground level or behind a concrete head wall, again reducing risks associated with human interference.

Recharge Areas

The recharge areas for the groundwater aquifer are situated south of the Bore and Storage Tank complex, covering an area of approximately one square kilometre. This area is sited at a higher altitude than the previous Rocky Valley Dam source, is relatively close to, but at a higher altitude than the village, and is located entirely within the boundaries of the Falls Creek Resort (which, itself, is bordered on all sides by the Alpine National Park).

The only water quality hazards in the recharge areas relate to faecal contamination from native and feral fauna. This is considered to be quite a low risk due to the surface slope which could reasonably be expected to quickly wash any faecal material to lower areas, away from the recharge areas.

Groundwater quality

The quality of the groundwater has been closely investigated. The results indicate a high quality, but very soft and unbuffered water source. The composition of water from the Horizontal Bores is very similar to the composition of the Production Bore, indicating similar sources. The Horizontal Bores, however, have slightly lower pH, Suspended Solids and Turbidity.

Potential contaminants investigated in these groundwater sources included heavy metals, organics including pesticides, and radiological parameters. All analytes were found to be lower than Health Guideline Values in Australian Drinking Water Guidelines 2011 (ADWG).

1.1.4 Back up Rocky Valley Dam supply – Surface Water

The catchment area for the Rocky Valley Dam water supply is a well vegetated, high altitude location which forms part of the Alpine National Park. There is limited recreational access to the catchment areas with skiing activities in winter and hiking and sailing activities in summer.

The current Alpine National Park Management Plan for the Bogong Unit specifically nominates water supply and catchment protection as one of the three primary Park management objectives. Further, as a management objective, the plan stipulates protection of water catchments as the highest priority.

Within the National Park, there are no dwellings or human habitation of any kind, no farming or agricultural activity of any kind and no other industrial or mining activity. To ensure that these protections are maintained, Parks Victoria have a range of compliance and enforcement powers. FCARMB also exercises significant controls over land use and visitor activity within the resort area.

Water from the lake is pumped to a pair of enclosed 0.6 ML Settling Tanks by three pumps (duty/stand-by/back-up, total capacity of 30 L/S). Residence time in the Settling Tanks is in the range 10 - 24 hours, depending on demand. There is no telemetry to the Pumping Station or the Settling Tanks, but these infrastructure elements are inspected daily when the system is operational. Water flows under gravity from the settling tanks to the Brown and Blue Storage Tanks, which are monitored with telemetry and alarmed for a level below 80 % of capacity.

The Rocky Valley Dam is managed and operated by AGL Hydro and is used for water supply to Falls Creek Alpine Resort and for the generation of hydroelectricity. Its capacity of 28,000 ML provides substantial residence time to allow removal of sediment.

Rocky Valley Dam has a history of stratification around mid-summer, usually mid- to late-January and to a lesser extent in mid-winter depending on ice build-up on the surface. During the summer lake stratification events, elevated levels of iron (Fe) and manganese (Mn) may be observed. These contaminants are released by anoxic reactions of vegetative sediment at the bottom of the lake, especially ash-laden sediment inflows after bushfires. They create the appearance of dirty water and absorb UV light. Previous options available to FCARMB to manage these contaminants are aeration of the dam or utilising alternate off-takes (from an aqueduct which runs above the village and into the lake, or from the snow making water supply drawn from a floating pontoon at the deepest part of the lake). FCARMB now avoid the use of the dam during the summer stratification periods as the bore has sufficient capacity to cope with demand.

1.1.5 Header Storage Tanks (Brown and Blue Tanks)

The water storage consists of two 1.5ML storage tanks. These tanks store 300% of current daily maximum demand and provide a buffer in the event of infrastructure failure.

These tanks have locked roof hatches and access locations near the base. They are externally inspected on a weekly basis and are bi-annually drained to permit a detailed internal inspection (one tank per year, alternating each year).

1.1.6 UV Treatment

Water entering the reticulation from the storage tank is disinfected using UV treatment. The UV disinfection plant installed at Falls Creek is adequate to safely disinfect the raw water under normal circumstances and under higher demand than at present.

Further information regarding the UV treatment system is contained in *Section 2 Drinking Water Treatment Processes*

1.1.7 Reticulation system

Treated water flows from the disinfection plant to consumers through the reticulation system. The reticulation system is comprised of nearly 4 km of pipe, most of which is rubber ringed cement lined ductile iron (DICL) pipe, with some un-plasticised Polyvinyl Chloride (uPVC). Condition assessments have indicated that there is a low risk of corrosion failure over the next thirty years. The network is inspected every five years as a part of the preventative maintenance program. Water jetting is executed if the visual inspection indicates that it is required.

The reticulation system supplies a permanent population of approximately 200 people during Summer with short-term summer event populations reaching up to 3500 people and winter resident populations of up to 5600 people. Water samples are collected from four locations throughout the reticulation system.

1.2 Implications for Risk Management

1.2.1 Groundwater Supply

The Production and Horizontal Bores associated with the groundwater source are well sealed from ingress. This means that the risk of direct inflows of contaminated water into the boreholes is very low. The recharge area for the underground aquifer is relatively close to the village and at a higher altitude than the previous Rocky Valley Dam source. All the pipework between the bore surface casings and the Accumulation Tank are underground to prevent damage and freezing during winter.

While these features may not be expected to impact the likelihood of faecal contamination from native and feral animals, the likelihood of risks attributable to human activities, such as rubbish dumping, spills, defaecation in open areas, and malicious damage are expected to be lower than comparable risks in the more isolated National Park environment of the Rocky Valley Dam catchment. The groundwater source has no hazard which is analogous with "human activities on the storage".

In summary, there are no major water quality hazards for the, groundwater-based, Falls Creek Water Supply. The hazards to water quality that do exist are relatively low and are either eliminated or reduced to acceptable levels by the treatment processes employed.

Weekly water quality analyses confirm this assessment. They show that no E. coli has been detected in the untreated groundwater samples collected in the past 12 months.

1.2.2 Rocky Valley Dam Backup Supply

The Rocky Valley Dam supply is tasked as a back-up supply, had very few significant risks to water quality. It was derived from a near-pristine catchment that was enclosed within the Alpine National Park. The most significant water quality risks to this supply have been identified in past risk assessments as:

- human activities in the catchment (skiing, bushwalking, camping, dumping, fuel spills);
- faecal contamination from native and feral animals in the catchment;
- excessive concentrations of Iron and Manganese during summer lake inversion events; These parameters are monitored six-monthly and shown in **section 4, table 7**.
- human activities on the storage (boating and fishing);
- fire in the Alpine National Park.

Historically, water quality testing of raw water from the Rocky Valley Dam supply revealed very few E. coli detections. This corroborates the above conclusion that there are very few significant risks to water associated with the surface supply from Rocky Valley Dam.

1.3 Implications for Emergency Management

The low risk levels identified in the above description have enabled the development of robust preventive measures and risk mitigation strategies. These will reduce the likelihood of any emergency or incident that may reasonably arise in relation to the supply. Further, since most of the preventive and risk mitigation measures have been incorporated into the design of installed infrastructure, there are few procedures and strategies that need to be considered during an emergency or incident.

The primary concern for the water supply emergency relates to depletion of storage due to leaks and/or large consumption from a village fire event.

Emergency events placing higher demand on the water supply can be satisfied using two additional water sources;

- Rocky Valley Dam – raw water can be supplied at 35L/s from the settling tanks
- Falls Creek Ski Lift Company – raw water can be supplied at 50L/s through snow making infrastructure. This water is sourced from Rocky Valley Dam.

In the event of an emergency and high demand, the UV systems have the capability to treat and supply safe, compliant drinking water at 120L/s.

1.4 Demand

System demand varies with seasonal visitation and the average daily flow fluctuates from around 0.2 megalitres per day (ML/d) up to 1.1 ML/d during the peak of winter (population approx. 5600). The total volume consumed from the supply sources for the last four years is as per Table 1 below.

Table 1: Annual Water Diversions

Year	Volume Diverted (ML)
2020-21	117
2019-20	143
2018-19	166
2017-18	169

Water consumption for the 2020-21 reporting period was again reduced compared to average annual consumption. The continued effects of COVID19 and mandatory alpine resort lockdowns has impacted visitation to the resort during both the 2020 and 2021 winter seasons. Water consumption in the 2020-21 reporting period was down 30% on the average annual supply.

The monthly diversions for the past two reporting periods are shown in the graph below.

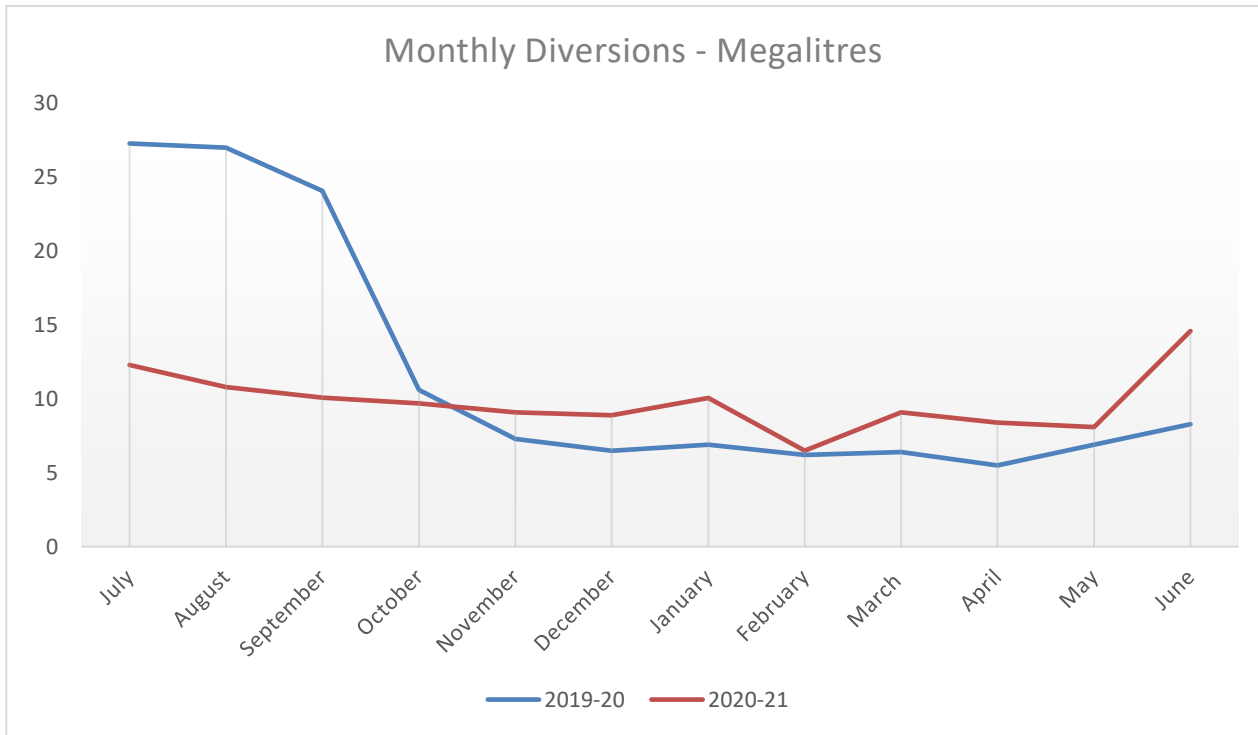

2 Drinking Water Treatment Processes – r. 16(e)

2.1 Water Treatment

2.1.1 Accumulation Tank and Calcite Filter

Water from the Production Bore and the Horizontal Bore is first collected in a 10kL Accumulation Tank. The very low measurements of both hardness and TDS in the groundwater meant that this water was relatively unbuffered and hence subject to pH excursions. The pH of the groundwater was observed in the range 5.5 – 5.8, which is outside the ADWG recommended range of 6.5 – 8.5. It is noted that the ADWG does not specify a Health Guideline Value and this range relates to aesthetic considerations. The hazard associated with low pH relates to the increased potential for corrosion and the subsequent dissolution of copper in pipe-work and brass fixtures.

The conventional treatment for these conditions involves passing the groundwater with through a Calcium Carbonate media. This is designed to increase the hardness of the water and stabilise any Carbonic Acid related pH excursions. The filtration capacity of the calcite filter may also reduce any suspended solids and turbidity in the groundwater.

The introduction of the Calcite Filter has achieved the desired effect. After calcite filtration, it was found that:

- pH increased from 5.8 to 6.8;
- Total Dissolved Solids increased from 21 to 91 mg/L;
- Electrical conductivity increased from 11 to 100 μ S/cm; and
- Suspended solids decreased from 11 to less than 2 mg/L.

The Calcite Filter includes an alarmed pH monitor and is maintained with a periodic backwash and disinfection with Sodium Hypochlorite. This removes any traces of suspended solids or micro-organisms within the groundwater that may have collected and accumulated in the calcite medium. The backwash water is discharged to the drainage system.

2.1.2 UV Treatment

The UV Treatment Plant consists of two UV units incorporating 50:50 stream split duty cycling between the two units to ensure that both units are always available for duty, without any warm-up time lag. The UV systems are capable of treating and supplying compliant, safe, drinking water at 120L/s.

The UV Transmittance (UVT) analyser measures the UV transmittance of the incoming water from the Brown/Blue Storage Tanks as well as any reduction in the UV-C output from the lamps, due to aging. This UV transmittance, together with flow data, is communicated to each UV treatment unit via the UV plant automation system and the UV treatment unit adjusts the UV intensity to achieve the required water sanitisation conditions for the measured transmittance and flow rate.

The operation of the entire UV treatment process is visible on the SCADA system. The operator console displays the total flow through each UV unit, the instantaneous flow through each UV unit, the instantaneous UV intensity generated within each UV unit, and the raw water UV transmittance. As part of verification monitoring, FCARMB ensure that the control room instrumentation is consistent with UV Treatment Unit readings undertaken as part of the daily system checks.

The UV Treatment Plant also includes a UPS and back-up generator rated to the full system load.

Table 2: Drinking Water Treatment Processes

Locality	Treatment Plant	Treatment Process	Added Substances	Comments
Falls Creek	Calcite Filter	Contact with Calcium Carbonate	Sodium hypochlorite	Sodium hypochlorite used for periodic backwash of calcite filter
	Disinfection Plant	UV treatment	Nil	

2.2 Issues

There were no issues with the operation of the disinfection system for the reporting period.

2.3 Chlorine based disinfection by-product chemicals

Falls Creek does not use chlorine-based disinfection products as a method of disinfection. Sodium Hypochlorite is only used twice annually to disinfect the reticulated network as a part of our preventative maintenance program.

Although chlorine is not used as a primary disinfection product THM's are monitored monthly as a part of the sampling program.

The results for THM's are shown in table **6 in section 4**.

3 Emergency, Incident and Event Management - r. 16(a) & 16(b)

Although preventive strategies are intended to prevent incidents and emergency situations from occurring, some events cannot be anticipated or controlled, or have such a low probability of occurring that providing preventive measures would be too costly. For such incidents, there must be the ability to respond promptly, constructively and efficiently.

There are a number of hazards or events that can lead to emergency situations, including:

- Treatment/disinfection failure;
- Failing to meet guideline values and other requirements;
- Accidents that increase levels of contaminants (e.g. spills in catchments, incorrect dosing of chemicals);
- Equipment breakdown and mechanical failure;
- Prolonged power outages;
- Extreme weather events (e.g. flash flooding, cyclones);
- Natural disasters (e.g. fire, earthquakes, lightning damage to electrical equipment); and
- Human actions (e.g. serious error, sabotage, strikes).

FCARMB has a Municipal Emergency Management Plan (MEMP) as required under the *Emergency Management Act 1986* and this plan is regularly updated and audited. The action statement for a drinking water supply incident is detailed in Appendix C of the plan to meet the requirements of the Regulations. The plan includes details of or clear references to emergency management arrangements and procedures for dealing with an incident, event or emergency that may adversely affect the quality or safety of drinking water, or result in water being supplied that poses a risk to human health, including:

- the positions held by persons responsible for dealing with such an incident, event or emergency; and
- methods for disseminating information to the public in relation to any such incident, event or emergency;

The arrangements and documented procedures have been followed and modified, where the debrief meeting for a particular incident/event/emergency has identified that the procedure required modification.

The MEMP is audited every three years, however is reviewed dynamically throughout the year as part of the Municipal Emergency Management Planning Committee process.

The Municipal Emergency Management Plan was revised in 2021 and approved by the Hume Regional Emergency Management Planning Committee on 14th May 2021.

3.1 Known or Suspected Contamination Reported Under Section 22

There were no incidents that were reported to DH under Section 22 of the Act.

3.2 Situations not reportable under s. 22 which impacted or had the potential to impact the water quality, but not the safety, of the water supplied

There were no incidents which impacted the safety or quality of drinking water supplied during the reporting period.

3.3 Staff and Resourcing for Water Operations Department

The staff that are involved in the water operations department and their relevant qualifications are listed in the table below.

Table 3: Water Department Staff

Staff	Name	Service	Qualifications
Director of Infrastructure & Mountain Response	Callum Brown	8 years	Bachelor Engineering – Mechanical
Asset & Operations Manager	Fred Weir	13 years	Diploma of Water Industry Operations Diploma of Project Management
Water Treatment Plant Operator	Dave Hunt	12 years	Certificate III in Water Treatment
Trainee Water Treatment Plant Operator	Jack Percy	12 months	Certificate III in Water Treatment – Underway. Scheduled for completion December 2021

4 Drinking Water Quality Standards – r. 16(f), 16(g) & 16(h)

4.1 Safe Drinking Water Regulations 2015

Drinking water supplied is required to meet water quality standards. All drinking water supplied at Falls Creek was compliant with the drinking water quality standards, and there was no notification was made to DH under s. 18 of the Act.

As per guidance page 10: Drinking water quality standards are specified in r. 12(a) and r. 12(b). Three drinking water quality standards are specified in Schedule 2 of the Regulations. Regulation 12(b) refers to drinking water quality standards not specified in Schedule 2, but are identified within the drinking water sampling program.

4.2 Schedule 2 Drinking Water Quality Standards – r. 12(a)

4.2.1 *Escherichia coli* (E. Coli)

Standard as stated in Schedule 2 of Safe Drinking Water Regulations 2015: All samples of drinking water collected are found to contain no *Escherichia coli* per 100 millilitres of drinking water, with the exception of any false positive sample.

Presentation of the results for the reporting period, and the previous two financial years, are shown in the following table.

Table 4: E. Coli Sampling Results

Year	Sampling Frequency	No. of samples*	Maximum detected (orgs/100mL)	Number of detections and investigations conducted (s. 22)	No. of samples where standard was not met (s. 18)
2020-21	Weekly	104	0	0	0
2019-20	Weekly	104	0	0	0
2018-19	Weekly	104	0	0	0

* Two locations are tested for E.coli weekly. One in the reticulated network and the UV disinfection system. Therefore 104 weekly results were received.

4.2.2 Turbidity

Standard as stated in Schedule 2 of Safe Drinking Water Regulations: The 95th percentile of results for samples in any 12-month period must be less than or equal to 5.0 Nephelometric Turbidity Units (NTU)

Presentation of the results for the reporting period, and the previous two financial years, are shown in the following table.

Table 5: Turbidity Sampling Results

Year	Sampling Frequency	No. of samples	Maximum turbidity in the sample (NTU)	Maximum 95 th percentile of turbidity results in any 12-months (NTU)	Number of 95 th percentile of results in any 12-months above the standard
2020-21	Weekly	52	3.7	1.7	0
2019-20	Weekly	52	4.9	2.6	0
2018-19	Weekly	52	3.4	1.5	0

Table 6: THM's

Water Sampling Locality	Sampling Frequency	No. of samples	Drinking Water quality standard (mg/L)	Maximum (mg/L)	Average (mg/L)	Number of samples where standard was not met (s.18)
Falls Creek Village Water Supply	Monthly	6*	0.25	0.008	0.0043	0

*Monitoring for THM's commenced January 2021. Therefore, only six results were received for the 2020-21 reporting

4.3 Other water quality parameters monitored that may pose a risk to human health – r. 12(b)

FCARMB has consistently delivered good quality and safe drinking water. All parameters monitored have met the health guideline values stated in the ADWG during the last three reporting periods. Data recorded since 1997 shows that, apart from copper and manganese, all of these parameters have continually tested below the detectable limits. This is due to the combination of high-quality source water and good risk management practices. The results from the analysis of these parameters from samples collected from the groundwater source are all below the detectable limits and meet water quality standards.

Results for the reporting period are as shown in the Table below. All tested parameters met the health guideline values in the ADWG.

Table 7: Health Risk Parameters Sampling Results**Ground water**

Parameter	Frequency of Sampling	Number of Samples	Drinking water quality standard (mg/L)	Maximum test value (mg/L)	Standard Met
Arsenic	6-monthly	2	0.01	<0.001	YES
Cadmium	6-monthly	2	0.002	<0.0002	YES
Chromium	6-monthly	2	0.05	<0.001	YES
Copper	6-monthly	2	2	0.001	YES
Lead	6-monthly	2	0.01	<0.001	YES
Manganese	6-monthly	2	0.5	0.002	YES
Mercury	6-monthly	2	0.001	<0.0001	YES
Nickel	6-monthly	2	0.02	<0.001	YES
Selenium	6-monthly	2	0.01	<0.001	YES
Sulphur	6-monthly	2	250	<0.5	YES
Radium*	Biennial	1	0.5Bq/L	<0.05	YES

*2018 Radium sample was missed. Refer to section 4.5.

Table 8: Health Risk Parameters Sampling Results
Surface water

Parameter	Frequency of Sampling	Number of Samples	Drinking water quality standard (mg/L)	Maximum test value (mg/L)	Standard Met
Arsenic	6-monthly	2	0.01	<0.001	YES
Cadmium	6-monthly	2	0.002	<0.0002	YES
Chromium	6-monthly	2	0.05	<0.001	YES
Copper	6-monthly	2	2	0.019	YES
Lead	6-monthly	2	0.01	<0.001	YES
Manganese	6-monthly	2	0.5	0.005	YES
Mercury	6-monthly	2	0.001	<0.0001	YES
Nickel	6-monthly	2	0.02	<0.001	YES
Selenium	6-monthly	2	0.01	<0.001	YES
Sulphur	6-monthly	2	250	<0.5	YES
Radium*	Biennial	1	0.5Bq/L	<0.05	YES

*2018 Radium sample was missed. Refer to section 4.5.

Table 9:
Pesticide Analysis Results December 2020 **Ground Water** **Surface Water**

		Ground Water	Surface Water
OCP (LL) - Aldrin	mg/L	<0.00001	<0.00001
OCP (LL) - BHC (Alpha Isomer)	mg/L	<0.00005	<0.00005
OCP (LL) - BHC (Beta Isomer)	mg/L	<0.00005	<0.00005
OCP (LL) - BHC (Delta Isomer)	mg/L	<0.00005	<0.00005
OCP (LL) - cis-Chlordane	mg/L	<0.00001	<0.00001
OCP (LL) - trans-Chlordane	mg/L	<0.00001	<0.00001
OCP (LL) - Chlordane	mg/L	<0.00001	<0.00001
OCP (LL) - 4,4'-DDD	mg/L	<0.00006	<0.00006
OCP (LL) - 4,4'-DDE	mg/L	<0.00006	<0.00006
OCP (LL) - 4,4'-DDT	mg/L	<0.00006	<0.00006
OCP (LL) - Dieldrin	mg/L	<0.00001	<0.00001
OCP (LL) - Endosulfan I	mg/L	<0.00005	<0.00005
OCP (LL) - Endosulfan II	mg/L	<0.00005	<0.00005
OCP (LL) - Sum of alpha-, beta- and Endosulphan Sulphate	mg/L	<0.00005	<0.00005
OCP (LL) - Endosulphan Sulphate	mg/L	<0.00005	<0.00005
OCP (LL) - Endrin	mg/L	<0.0001	<0.0001
OCP (LL) - Endrin Aldehyde	mg/L	<0.0001	<0.0001
OCP (LL) - Endrin Ketone	mg/L	<0.00005	<0.00005
OCP (LL) - Hexachlorobenzene	mg/L	<0.000002	<0.000002
OCP (LL) - Heptachlor	mg/L	<0.00005	<0.00005
OCP (LL) - Heptachlor Epoxide	mg/L	<0.00005	<0.00005
OCP (LL) - Lindane (BHC Gamma Isomer)	mg/L	<0.00005	<0.00005
OCP (LL) - Methoxychlor	mg/L	<0.0002	<0.0002
OCP (LL) - Oxy-Chlordane	mg/L	<0.0001	<0.0001
OCP (LL) - Sum of DDD, DDE and DDT	mg/L	<0.00006	<0.00006
OCP (LL) - Sum of Aldrin and Dieldrin	mg/L	<0.00001	<0.00001
OPP (LL) - Dichlorvos	mg/L	<0.001	<0.001
OPP (LL) - Monocrotophos	mg/L	<0.001	<0.001
OPP (LL) - Prophos	mg/L	<0.001	<0.001
OPP (LL) - Tetraethyldithiopyrphos	mg/L	<0.001	<0.001
OPP (LL) - Phorate	mg/L	<0.001	<0.001
OPP (LL) - Demeton-S	mg/L	<0.001	<0.001
OPP (LL) - Diazinon	mg/L	<0.001	<0.001
OPP (LL) - Methyl Parathion	mg/L	<0.001	<0.001
OPP (LL) - Ronnel	mg/L	<0.001	<0.001
OPP (LL) - Malathion	mg/L	<0.001	<0.001
OPP (LL) - Fenthion	mg/L	<0.001	<0.001
OPP (LL) - Chloropyrifos	mg/L	<0.001	<0.001
OPP (LL) - Parathion	mg/L	<0.001	<0.001
OPP (LL) - Trichlorinate	mg/L	<0.001	<0.001
OPP (LL) - Tetrachlovinphos	mg/L	<0.001	<0.001
OPP (LL) - Tukuthion	mg/L	<0.001	<0.001
OPP (LL) - Fensulfothion	mg/L	<0.001	<0.001
OPP (LL) - EPN	mg/L	<0.001	<0.001
OPP (LL) - Coumaphos	mg/L	<0.001	<0.001
PAH (LL) - Naphthalene	mg/L	<0.00001	<0.00001
PAH (LL) - Acenaphthylene	mg/L	<0.00001	<0.00001
PAH (LL) - Acenaphthene	mg/L	<0.00001	<0.00001
PAH (LL) - Fluorene	mg/L	<0.00001	<0.00001
PAH (LL) - Phenanthrene	mg/L	<0.00001	<0.00001
PAH (LL) - Anthracene	mg/L	<0.00001	<0.00001
PAH (LL) - Fluoranthene	mg/L	<0.00001	<0.00001

Pesticide Analysis Results December 2020 **Ground Water Surface Water**

PAH (LL) - Pyrene	mg/L	<0.00001	<0.00001
PAH (LL) - Benz(a)Anthracene	mg/L	<0.00001	<0.00001
PAH (LL) - Chrysene	mg/L	<0.00001	<0.00001
PAH (LL) - Benzo(b)Fluoranthene	mg/L	<0.00001	<0.00001
PAH (LL) - Benzo(k)Fluoranthene	mg/L	<0.00001	<0.00001
PAH (LL) - Benzo(a)Pyrene	mg/L	<0.000002	<0.000002
PAH (LL) - Dibenz(a,h)Anthracene	mg/L	<0.00001	<0.00001
PAH (LL) - Benzo(g,h,i)Perylene	mg/L	<0.00001	<0.00001
PAH (LL) - Indeno(1,2,3-cd)Pyrene	mg/L	<0.00001	<0.00001
PAH (LL) - Total PAH	mg/L	<0.00001	<0.00001
Phenols(Halo) - 4-Chloro-3-Methylphenol	mg/L	<0.001	<0.001
Phenols(Halo) - 2-Chlorophenol	mg/L	<0.001	<0.001
Phenols(Halo) - 2,4-Dichlorophenol	mg/L	<0.001	<0.001
Phenols(Halo) - 2,6-Dichlorophenol	mg/L	<0.001	<0.001
Phenols(Halo) - Pentachlorophenol	mg/L	<0.001	<0.001
Phenols(Halo) - 2,3,4,5-Tetrachlorophenol	mg/L	<0.001	<0.001
Phenols(Halo) - 2,3,4,6-Tetrachlorophenol	mg/L	<0.001	<0.001
Phenols(Halo) - 2,3,5,6-Tetrachlorophenol	mg/L	<0.001	<0.001
Phenols(Halo) - 2,4,5-Trichlorophenol	mg/L	<0.001	<0.001
Phenols(Halo) - 2,4,6-Trichlorophenol	mg/L	<0.001	<0.001
Phenols(Halo) - Total Phenols (Halogenated)	mg/L	<0.001	<0.001
Phenols(NonHalo) - Phenol	mg/L	<0.001	<0.001
Phenols(NonHalo) - 2-Methylphenol (O-Cresol)	mg/L	<0.001	<0.001
Phenols(NonHalo) - 3-Methylphenol (M-Cresol)	mg/L	<0.001	<0.001
Phenols(NonHalo) - 4-Methylphenol (P-Cresol)	mg/L	<0.001	<0.001
Phenols(NonHalo) - 2,4-Dimethylphenol	mg/L	<0.001	<0.001
Phenols(NonHalo) - 2-Nitrophenol	mg/L	<0.001	<0.001
Phenols(NonHalo) - 4-Nitrophenol	mg/L	<0.001	<0.001
Phenols(NonHalo) - Total Phenols (non Halogenated)	mg/L	<0.001	<0.001

*The 2019 Pesticide analysis was missed. Refer to Section 4.5

4.4 Drinking Water Quality Reports – s. 23

FCARMB met all water quality standards for the reporting period. Section 23 of the Act requires FCARMB to make available for inspection by the public the results of the water quality monitoring program. Customer and members of the public may access drinking water quality data by contacting FCARMB on (03) 5758-1200 during business hours or by email to fcrm@falls creek.com.au

4.5 Actions in Relation to Non-Compliance

During the 2020-21 compliance period there was an incident relating to the monitoring and sampling program that was reported to the Department of Health.

A customer enquiry identified that the Radium sample was missed from the 2018-19 monitoring period. Further investigation identified that the annual pesticide monitoring had also been missed from the program.

Both the Radium and pesticides analysis were undertaken in December 2020. The results are presented in this report, in tables 7, 8, and 9.

FCARMB committed to five actions as a result of the missed samples.

1. The quarterly water risk management meetings (per Appendix 4, Falls Creek Water Supply Risk Management Plan) now include specific review of monitoring and sampling data. This will be amended in the Risk Management Plan (RMP) document when it is revised in March 2022.
2. The quarterly monitoring and sampling review includes:
 - Confirmation that the sampling program has been executed in accordance with Appendix 10 of the RMP
 - Confirmation that sample test results were compliant during the period.
 - Review of test results trends and anomalies.
 - Review of plant monitoring data trends and anomalies.
 - Development of an action plan if required.
3. FCARMB will undertake a comprehensive review and update of the RMP prior to the next audit, nominally by March 2022. Elements of the review related to sampling will include:
 - Review and update of the Falls Creek water supply risk assessment
 - Review and update of the monitoring and sampling program appropriate for the resort water supply risk profile.
4. The review and update of the RMP will be undertaken by an appropriately qualified external consultant with expertise in water supply risk management, in conjunction with FCARMB responsible persons.
5. FCARMB will ensure the drinking water quality annual report for 2020/21 discloses the missed radiological and pesticide samples.

5 Aesthetic Guidelines

Drinking water parameters monitored to manage aesthetic quality of the water supply are presented in the following table. All parameters tested met the ADWG aesthetic guideline values for the reporting period.

Table 10: Aesthetic Parameters Sampling Results
Surface Water

Parameter	Frequency of Sampling	Number Samples	Units	Mean Value	Maximum test value	Minimum test value	ADWG Guideline
Total Dissolved Solids	Annually	2	mg/L	14.5	19	10	1000
Total Alkalinity	6-monthly	2	mg/L	6	8	4	N/A
Calcium	6-monthly	2	mg/L	0.8	0.9	0.7	N/A
Chloride	6-monthly	2	mg/L	1	3	<1	250
Hardness	6-monthly	2	mg/L	4.5	6	3	200
Iron	See Note	2	mg/L	0.36	0.46	.021	0.3
Magnesium	6 Monthly	2	mg/L	0.2	0.2	0.2	N/A
Potassium	6 Monthly	2	mg/L	0.4	0.6	0.2	N/A
Sodium	6 Monthly	2	mg/L	0.55	0.6	0.5	180
Zinc	6 Monthly	2	mg/L	<0.0045	<0.006	<0.003	3

*The dam was not in use when the samples were taken.

Table 11: Aesthetic Parameters Sampling Results
Ground Water

Parameter	Frequency of Sampling	Number Samples	Units	Mean Value	Maximum test value	Minimum test value	ADWG Guideline
Total Dissolved Solids	Annually	2	mg/L	21.5	35	8	1000
Total Alkalinity	6-monthly	2	mg/L	6.5	7	6	N/A
Calcium	6-monthly	2	mg/L	0.8	0.9	0.7	N/A
Chloride	6-monthly	2	mg/L	<1	<1	<1	250
Hardness	6-monthly	2	mg/L	3	3	3	200
Iron	See Note	2	mg/L	<0.01	<0.01	<0.01	0.3
Magnesium	6 Monthly	2	mg/L	0.25	0.3	0.2	N/A
Potassium	6 Monthly	2	mg/L	0.25	0.3	0.2	N/A
Sodium	6 Monthly	2	mg/L	1.1	1.2	1	180
Zinc	6 Monthly	2	mg/L	<0.001	<0.001	<0.001	3

Note: Until April 2017 testing for iron had been conducted on a weekly basis due to the stratification issues with the Rocky Valley Lake. Following the shift to groundwater as the primary supply source and following a comprehensive risk review and update to the risk management plan, testing is not conducted on a monthly basis. The parameter is now tested in Rocky Valley Dam when the surface water supply is in use. This is generally only during the peak winter months.

5.1 Actions undertaken where aesthetic guideline value is not satisfied.

There were no actions required where an aesthetic guideline was not met within the reporting period.

6 Water Quality Complaints – r. 16(j)

There were no complaints received from customers during this reporting period or the previous two reporting periods.

Table 12: Water Quality Complaints Summary

Type of Complaint	2020/21 No of Complaints	No. of complaints per 100 customers supplied.	2019/20	2018/19
Discoloured water	0	0	0	0
Taste/Odour	0	0	0	0
Blue water	0	0	0	0
Air in water	0	0	0	0
Suspected illness	0	0	0	0
Other	0	0	0	0

7 Risk Management Plan Audit Results – r. 16(d)

FCARMB conducted an audit of the Water Supply Risk Management Plan in April 2020. The audit is executed to ensure compliance with the conditions outlined in the Safe Drinking Water Act 2003, Section 7(1).

The audit is executed once every three years. Auditors must be certified under the Exemplar Global Incorporated Water Quality Management Systems and approved by DH.

Falls Creek Resort Management was found to be compliant with the conditions outlined in Section 7(1) of the *Safe Drinking Water Act 2003*

The audit report identified opportunities for Resort Management to ensure continuous improvement with water operations. The OFI's and FARMB responses are outlined in the table below

IDENTIFIED OFI	FCARMB Comments	Implementation Status
<i>A very high priority suggestion is to complete the additional water supply bore - this installation is only partially completed.</i>	Bore has been drilled. Amendment to extraction license submitted to Goulburn Murray Water.	Bore completed, commissioning and connection summer 2021/22
<i>It is also suggested as a very high priority to upgrade your SCADA software to the latest version - this will have many benefits and further strengthen your critical control points. There are new features, for example, alarms going to SMS messages on phones. We also suggest as part of this to further review the alarm protocols and training.</i>	The SCADA software was upgraded in January 2021. This project involved the addition of a backup server and increased security for the network.	Completed
<i>It is also very encouraging to note that as part of the review of the Standard Operating Procedure (SOP) for the flushing of pipework, this SOP task is now in the Maintenance Connection program, twice per year and the maintenance of the scouring system is once every five years.</i>	Noted	Completed
<i>Suggested this hypochlorite dosing installation is carefully reviewed by a specialist supplier and, for example, partially external to the UV plant room.</i>	A hypochlorite dosing system was commissioned in December 2020. The new dosing system is now monitored and controlled and alarmed via SCADA. The system has been used for network chlorination as a part of the preventative maintenance program.	Completed

<p><i>We also agree it's a high priority to install an emergency standby generator for the water pumps. There is a concern the water tanks would only have water for a limited period in the event of a power failure. It is also under review to also install this external to the UV plant room to prevent overheating of the UV control panel.</i></p>	<p>A new backup generator was installed and commissioned in May 2021. The new generator is sized to provide power to the groundwater pumps in the event of a power outage. This now removes reliability on Rocky Valley Dam in the event of a prolonged power outage.</p>	<p>Completed</p>
<p><i>We note that security cameras now installed in the primary drinking water tank areas. Suggest as a medium priority considering further upgrading this with more security cameras.</i></p>	<p>An internal review of the current camera network and water infrastructure did not highlight any areas that would benefit from additional cameras.</p>	<p>Additional cameras will not be implemented.</p>
<p><i>We note that Australian Gas Light who manages the lake has not yet supplied a copy of their report; it is under review to consider a yearly meeting instead. Suggest this a low priority, and when the new bore is operational this will no longer be a priority</i></p>	<p>This is not considered a high priority due to the reduced usage of Rocky Valley Dam. The surface water will be re-assessed as a part of the Risk Management Plan Review scheduled for March 2022.</p>	<p>This will be assessed as a part of the review of the risk management plan scheduled for March 2022.</p>
<p><i>Suggest also consider leak detection technologies; this will also help increase system visibility and should be able to identify where water leaks are occurring accurately; this again can help optimize resources. Though this is a lower priority as unscheduled water losses have been reduced via system improvements.</i></p>	<p>We are currently looking into smart meters and leak detection technology. FCARMB will engage a consultant to provide a recommendation on this.</p>	<p>The review and report will be executed in the FY22 reporting period.</p>

8 Undertakings – r. 16(c)

FCARMB does not have any undertakings with the Department of Health and Human Services.

9 Regulated Water – r. 16(l) & 16(m)

FCARMB does not manage any regulated water supplies.

10 Glossary of Terms and Further Information

Act.....	Safe Drinking Water Act 2003
ADWG.....	Australian Drinking Water Guidelines 2011
AWA.....	Australian Water Association
CMA.....	Catchment Management Authority
DH.....	Department of Health
DELWP	Department of Environment, Land, Water and Planning
DWQMS.....	Drinking Water Quality Management System
<i>E. coli</i>	<i>Escherichia coli</i> – organism that indicates faecal contamination. Used as an indicator of safe drinking water
EMP.....	Emergency Management Plan
EPA.....	Environment Protection Authority
FCARMB.....	Falls Creek Alpine Resort Management Board
kL.....	Kilolitre – 1,000 litres
ML.....	Megalitre – 1,000,000 litres
MOU	Memorandum of Understanding
NTU	Nephelometric Turbidity Units (see Turbidity)
OHS.....	Occupational Health and Safety
pH	Measure of the acidity or basicity of water e.g.: pH = 7 is neutral; pH < 7 is acidic; pH > 7 is basic
Potable.....	Drinkable, suitable for human consumption
Regulations.....	Safe Drinking Water Regulations 2015
Turbidity	A measure of the muddiness of water which may be caused by suspended fine clay particles, silts, algae, organic plant and animal debris
UV.....	Ultra Violet